

Deterrence Dispensed presents

but
what
about

AMMO

how to make 9mm rounds
in heavily regulated areas

1

IvanTheTroll
version 1.00

Preface

ButWhatAbout: Ammo is a project that explores DIY ammo manufacture under conditions where ammo is regulated, hard to obtain, or simply for hobby interest.

This is the first volume in ButWhatAbout: Ammo. It focuses on taking 'decorative' or 'deactivated' ammo (a fired case, used primer, and new bullet) and rearming it using Hilti nailgun blank cartridges (which can be obtained in many places legally where owning ammo is regulated). Future publications will focus on more broad attempts to DIY ammo, including manufacture of cases, primers, and even synthesis of the combustibles without relying on the loophole in which Hiltis exist.

While this process isn't necessarily a wholly unique discovery - Hiltis have been used to make ammo for many years now - I hope that having a comprehensive, viable way to source the components you need in many countries worldwide will be helpful.

Do note that while the process described here is quite safe, appropriate steps should be taken for your safety - wear safety glasses at all times, and leather gloves when handling the charged nailgun blanks.

This document will follow the process, tips, techniques, notes, and data I gathered while taking this project on - it should supplement the videos that accompany this document in allowing you to replicate my results on your own.

If you've found this tutorial useful, consider sending me Bitcoin to further development of this sort of thing - there's much more to explore in DIY ammo, DIY guns, and 3D printing.



Bitcoin: Tubed6E8i2J7pPp1MuASSjZpUkmunPcZgEogo16dggDWS7KFS74dq9TA
M9aTyVAGBrhM1gwvsafX9rjMMc1RstVgHko8Sy9iy3

For all those living under permanent suspicion of their governments,
Seeking a more equal, fair world,
In memory of those who died disarmed and hopeless,
And those who simply enjoy the art and hobby of shooting.

Remember that it is our shared responsibility to be safe and smart with firearms and show the world there is a peaceful way to own guns – take the time to get training, to learn basic (and advanced) safety rules, and to share the hobby with everyone interested – those most scared of guns in the hands of the people are often the ones who have no experience with guns in the first place.

TESTING RELEASE NOTICE

The information contained in this report is released in good faith as a process that has been shown to work safely and effectively. However, the number of people who have tested it has been small, and those people were all competent people with mechanical skills. If you choose to take up this process on your own, you do so at your own risk and hazard – the information and process is realized to be something that could used refined, so you may consider this release version (V1.0) to be a BETA TEST version – it is released so that people with varying skills and backgrounds can take it up, engage in it, and give feedback to improve it. You can provide your feedback by joining the Keybase team ‘Det_Dispatch’ (https://keybase.io/team/det_disp) and joining the subteam ‘bwa-ammo’.

Table of Contents

| | |
|--|----|
| Preface | 1 |
| Shopping List..... | 5 |
| Tooling Setup | 15 |
| The Process | 21 |
| Part 1: Harvesting Powder | 21 |
| Part 2: Rearming Primers..... | 24 |
| Part 3: Loading Rounds | 31 |
| Load Data | 35 |
| Existing Tests..... | 36 |
| Notes/Words of Wisdom/Quality Control..... | 37 |
| FAQ/Troubleshooting | 37 |
| Acknowledgements..... | 38 |

Shopping List

Some of the exact items on this list are flexible. I'll list the materials I used, and I recommend you stick to them – if you do go freestyling on your tools, bear in mind you may run into issues that can cause safety hazards.

For the combustible sources (Hilti blanks) I am going to avoid using links (which could be taken down, honeypotted, or otherwise monitored by fascist governments), and will instead offer terms you can search for so that you can exercise good caution and governments won't have easy targets to take down.

Note that if you can buy live primers online, you can avoid having to rearm the once-fired primers that this process includes – you can simply skip all of Part 2 except removing the old primers.

Hilti 6.8/11 Red, easily purchasable in all of Europe:

Search for "Hilti 6.8/11 Red" on Google and find construction supplier shops or try to find them on Ebay or the equivalent of Ebay from your own country. You can also search for "Hilti 416474" to find these.



(Note, you may need to change the word "red" for the word "red" in your local language, if your local language is not English)

.355 FMJ RN bullets, easily purchasable from following countries in Europe:

Czech Republic, Austria, Germany - Search for ".355 FMJ RN" or "9mm FMJ RN"



Cases with reloadable inert primer still inside, easily purchasable from following countries:

Poland – Search for "LUSKI 9x19mm" or "Lusek 9mm"

Germany – Search for "Hülsen 9mm gebraucht"

UK – Search for "deactivated 9x19mm"

Czech Republic – Search for "deco 9mm ammo" or "decorative 9mm ammo"



FIRED PRIMER

Cases without Primer, easily purchasable from following countries:

Czech Republic - Search for "Nábojnice 9mm"

Austria - Search for "9mm hülsen"

Germany - Search for "9mm hülsen"



Note: If you buy cases without primers, you must either buy new, live primers or used primers that you will reactivate using this tutorial's process.

Primers, easily purchasable from following countries:

Italy - Search for "Inneschi Small Pistol"



The following items are common, and I will leave it to you to source them.

1mm Punch (1.5mm Punch can work)



Diagonal Cutter Pliers

Do not get cheap diagonal cutters. Long handle pliers with stout jaws are preferred. Refer to the Part 1 video to see what mine look like.



Glass Container

Glass reduces the chance of electrical discharge – electrical discharge can cause accidents when working with combustibles.



Needle-Nosed Pliers



Small Screwdriver (2mm or smaller), or a 'Dental Pick' Style Tool



Small Hammer



Flat, hard surface (metal block or a wooden block) – literally just a metal block.



3.5mm Punch (3mm Punch can work)



M4 Bolt (between 12 and 16mm thread length)



Tabletop Vise (C-Clamp can work)



Electronic Scale



3.5mm Hole Punch
<http://ebay.us/red1fn>



Tooling Setup

The tooling setup for this process is quite simple – most tools will be used outright, as they are intended to be (without modification).

The tools that will need a little attention will be the printed ones. If you do not have proper reloading equipment and can't get it (a setup like the one used in this video: <https://www.youtube.com/watch?v=X1aW0BFzLtU>), then you will have to print the following tools. Refer to the video tutorial for how exactly to use these tools.

Case Sizer Tool (Left and Right side)

Find files 'Case Sizer Left.stl' and 'Case Sizer Right.stl' in the STL folder.

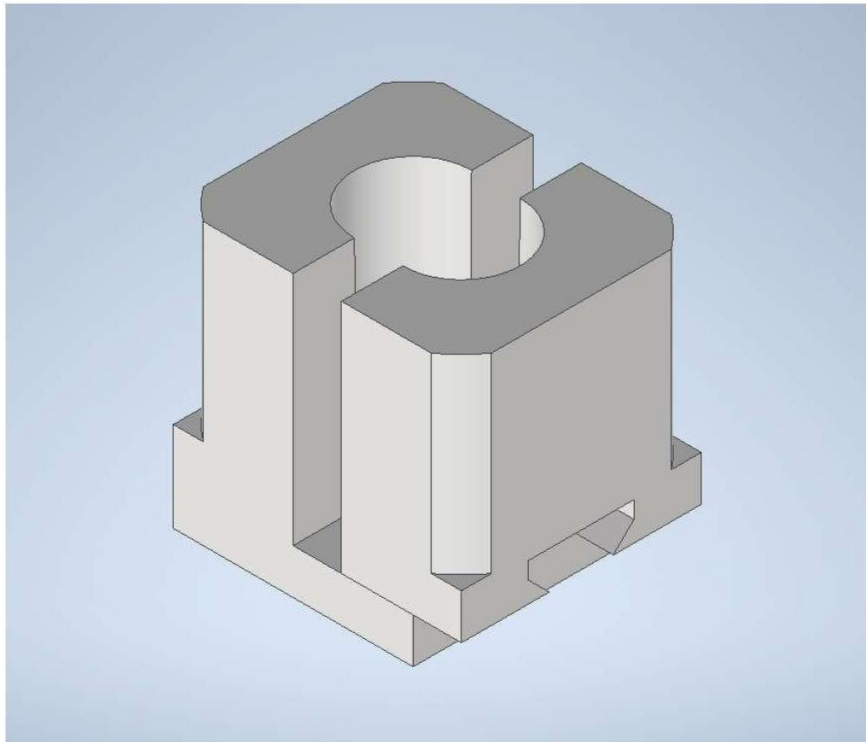

This part should be printed upright (the STLs included are oriented and scaled correctly) with supports enabled at a 45deg threshold. I printed in eSun PLA+, 100% infill. After printing, remove all supports from the parts and slide the tool together on its track. It will be stiff the first time you slide it together, using your vise or c-clamp to close it is recommended.

Note: This tool has a limited lifespan when used to reload cases, replace both sides about every 20 rounds you reload.

Primer Seating Tool Male Side

Find file 'Primer Seating Tool Male.stl' in the STL folder.

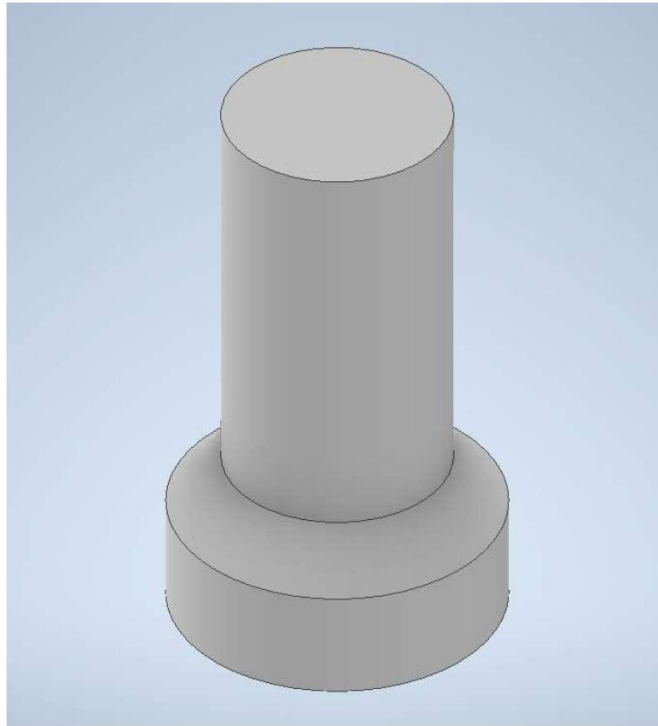

This part should be printed upright (the STLs included are oriented and scaled correctly) without supports. I printed in eSun PLA+, 100% infill. This tool is used to protect the case mouth from the jaws of your vise or c-clamp as you press the primer into position.

Primer Seating Tool Female Side

Find file 'Primer Seating Tool Female.stl' in the STL folder.

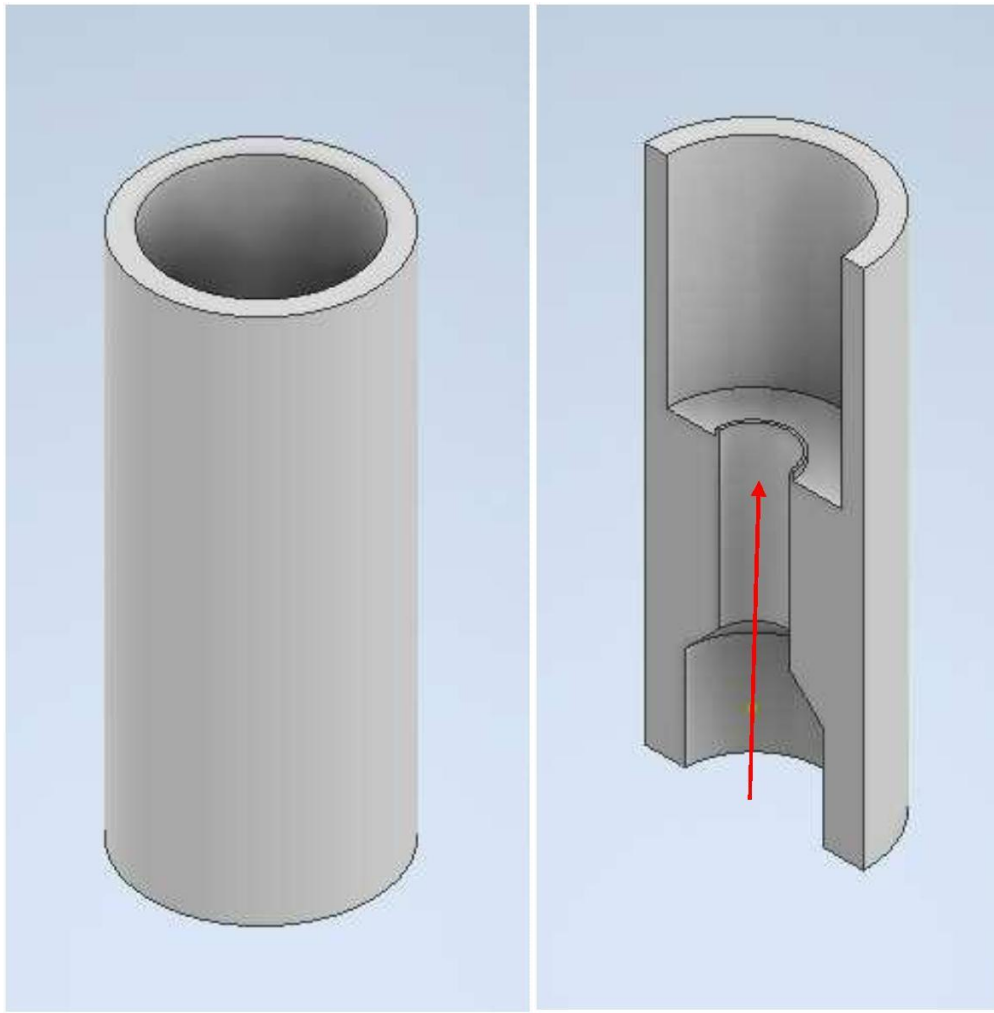

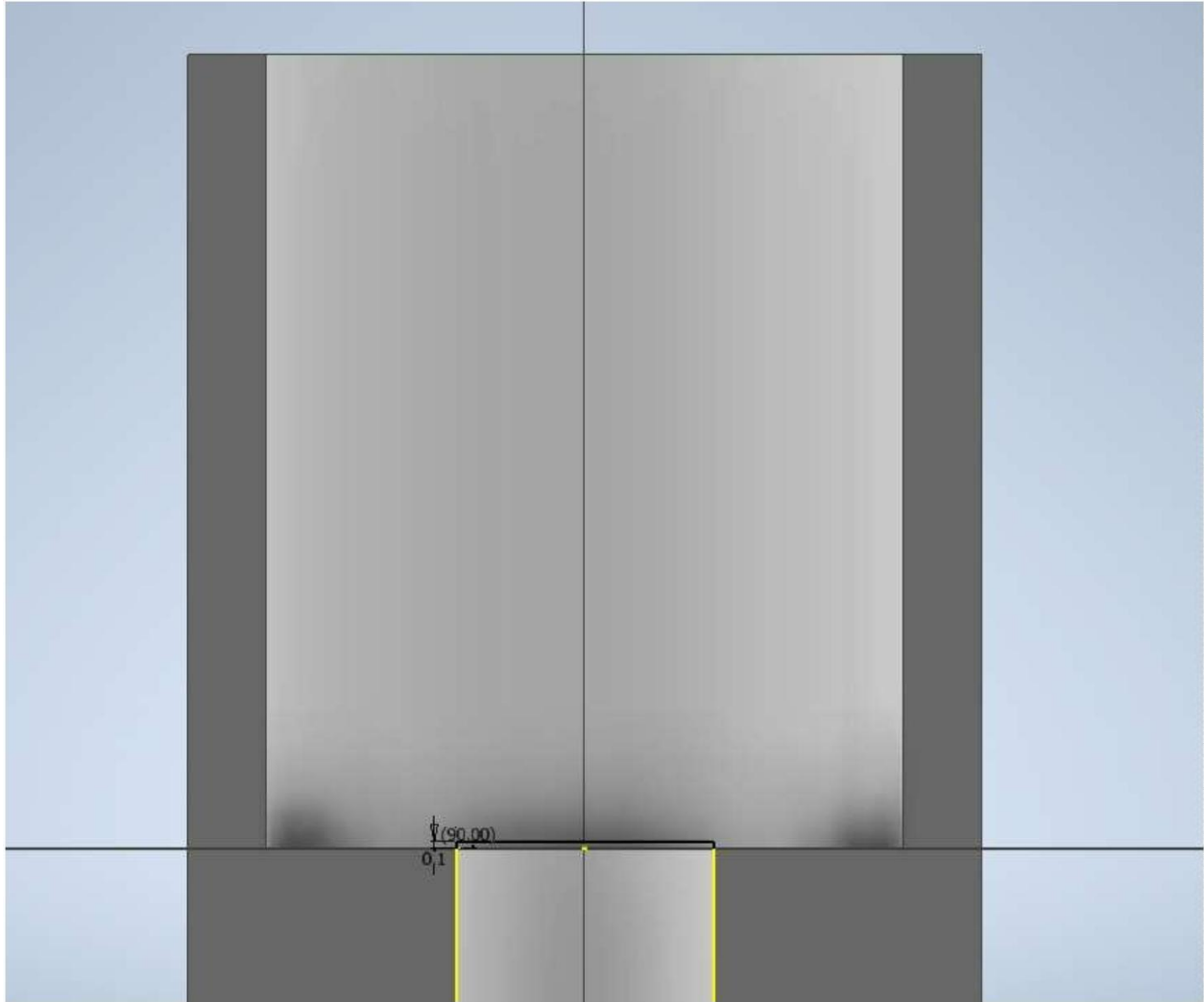

Bolt should stick up roughly 0.1mm from the bottom of the pocket

This part should be printed upright (the STLs included are oriented and scaled correctly) without supports. I printed in eSun PLA+, 100% infill. After printing, take your 16mm bolt (this bolt could be as short as 12mm) and insert it in the direction shown on the picture on the left above. You will screw in this bolt until about 0.1mm of the bolt sticks up past the bottom of the pocket (this will be about one full turn of the bolt from the point it is flush with the bottom of the pocket). While this does not need to be very precise, if you get 0.1mm of the bolt sticking up past the bottom of the cup, you can avoid accidentally setting off primers when pressing them into cases. You will be using the part of the bolt that sticks up to press against the primers as you press them in.

Case Mouth 'Flare'/Rounding Tool

Find file 'Case Mouth Tool.stl' in the STL folder.

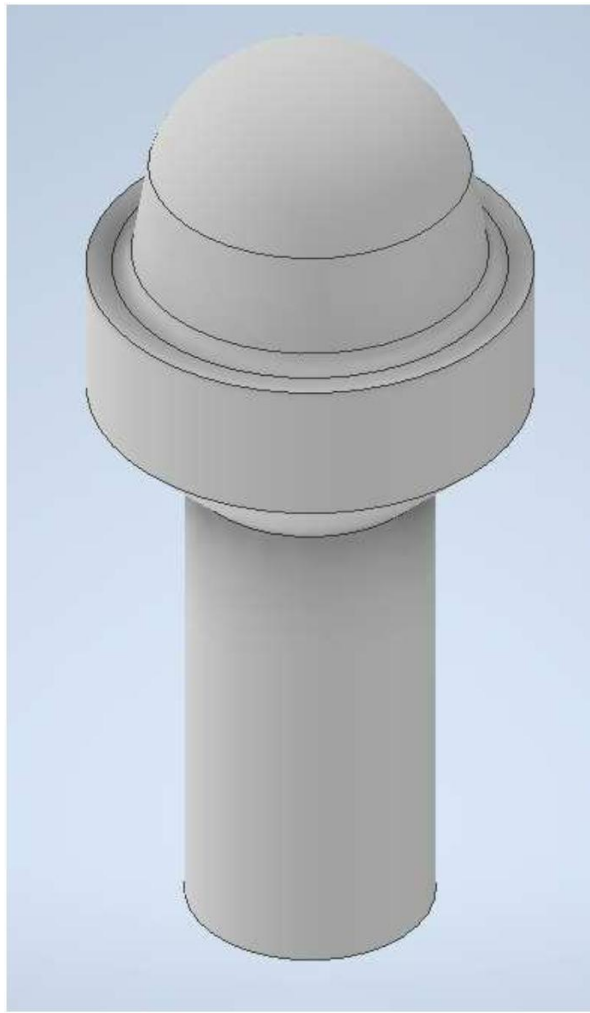

This part should be printed upright (the STLs included are oriented and scaled correctly) without supports. I printed in eSun PLA+, 100% infill. This tool is used to round out case mouths that are damaged or dented, as well as for slightly opening case mouths that you have trouble getting bullets to seat in.

Note: This part has a limited lifespan when used to fix case mouths. It should be replaced after 5 – 10 uses, or when it stops working properly.

Primer Removal Cup

Find file 'Primer Removal Cup.stl' in the STL folder.

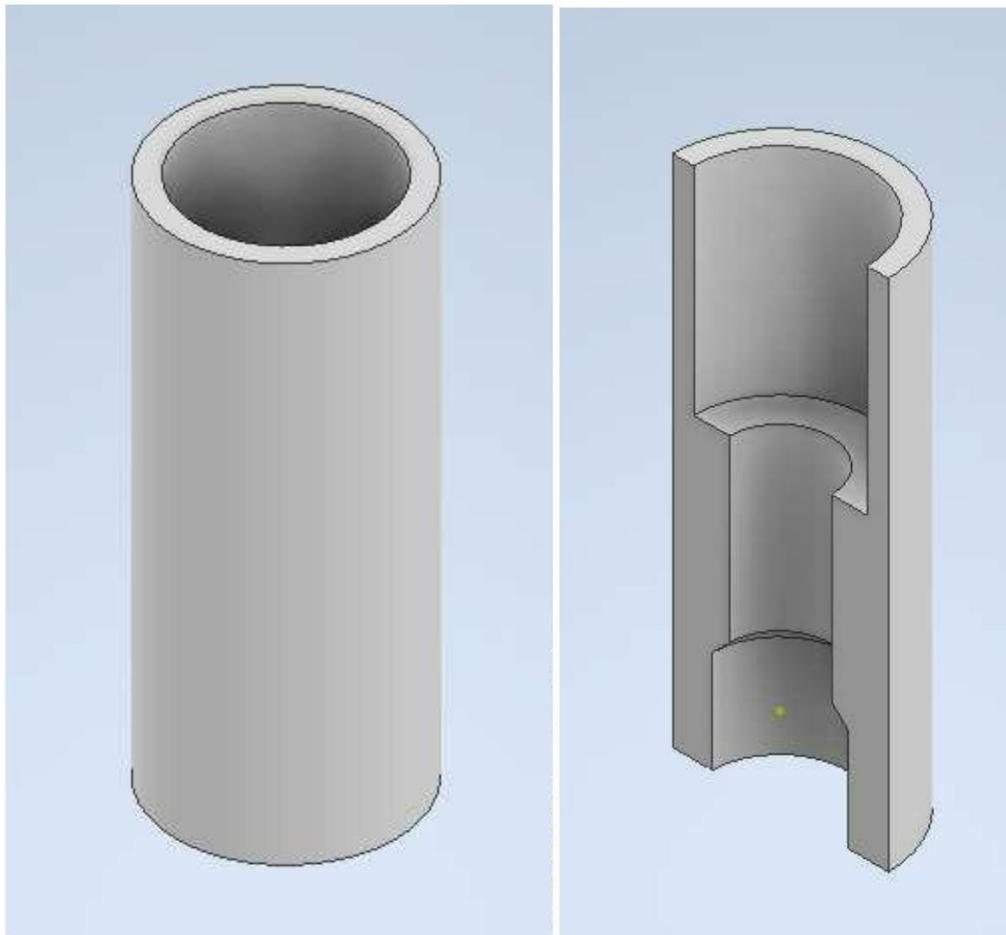

This part should be printed upright (the STLs included are oriented and scaled correctly) without supports. I printed in eSun PLA+, 100% infill. This tool is used in Part 2 and takes the place of the 3/8" Socket that I used in the video. This tool is to be used the same way as the socket was – you place a case in the top pocket and punch the primer out the bottom of the case.

The Process

This section will cover the process of rearming ammo, step-by-step. This section is meant to supplement the video tutorial, which demonstrates this process in real-time. You can download a video tutorial of this entire process here: <https://bittube.video/videos/watch/70d93aee-e0bf-4b6f-943a-89d1a8a59d90>

Note: If you have managed to purchase commercial primers, you can skip most of Part 2, as Part 2 deals mostly with rearming primers. The only step you need follow in Part 2 is removing the primers from the cases, which is the first step.

Note: If you are re-arming primers, it will take about 7 Hiltis worth of priming compound to rearm 5 primers. Because you will only be using 4.3gr of powder per reloaded round at most, you will have a surplus of powder that will begin to accumulate as you reload more and more rounds. You can burn this to get rid of it or store in in a glass jar WITH A PLASTIC LID (no metal).

Part 1: Harvesting Powder

This part involves taking your fresh Hiltis, opening their crimp, removing the powder from them, and storing that powder for later. Refer to this video for a live demo of this Part:

<https://bittube.video/videos/watch/70d93aee-e0bf-4b6f-943a-89d1a8a59d90>

(You can download this video along with the other Parts here):

<https://bittube.video/videos/watch/70d93aee-e0bf-4b6f-943a-89d1a8a59d90>

NOTE: I RECOMMEND YOU WEAR LEATHER GLOVES AND A FULL FACEMASK FOR THIS PART.

- Step 1: Remove your Hiltis from their strip (if your Hiltis did not come loose already). Use needle-nosed pliers to squeeze them out of the strip. Complete this for as many Hiltis as you plan on harvesting.

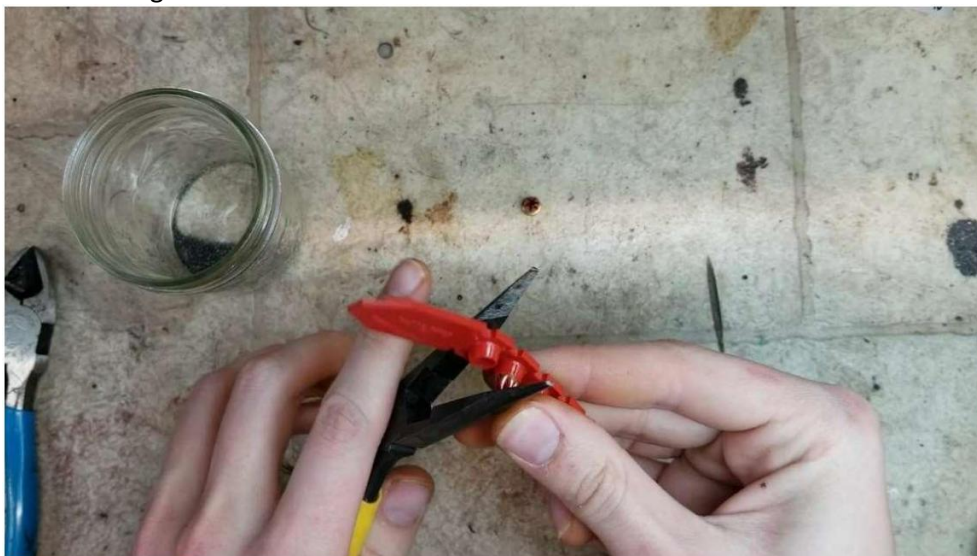

Step 1

- Step 2: Pinch the crimp of the Hilti with your side-cutter pliers. You are trying to get the point of the crimp to blossom open. This may take a couple tries to get the hang of, but once you have got it figured out it is a breeze.

Note: Do not attempt to tap or pry the mouth of the Hilti open until ALL of the gunpowder is removed – if you accidentally set off the priming compound with no powder in the case, you will be fine. If the case still has powder in it, you are taking a huge risk.

Note: Do not attempt to pinch anywhere near the bottom (ESPECIALLY NOT THE RIM) of the Hilti – I set one off on accident doing this (pinching close to the bottom) when it was full of powder and chewed up my hand. Unless you want to have to dig gunpowder flakes out of your muscle, I would advise you wear gloves and pinch on the CRIMP, not near the base.



Part 2: Proper pinching location.

- Step 3: Pour out the powder through the opening in the crimp. Tap your hands together while holding the Hilti to help the powder spill out. After you have done this enough times you'll be able to visually gauge when all of the powder has spilled out of the Hilti. After you have emptied the Hilti, set it to the side and go back to Step 2 for your next Hilti. Repeat until all the Hiltis you plan on harvesting are empty.



Step 3: Emptying the powder into a glass container.

Part 2: Rearming Primers

This part involves taking your fired brass, removing the fired primers from them, and re-arming those primers using the compound in your Hiltis. Refer to this video for a live demo of this Part:

<https://bittube.video/videos/watch/a1653cc6-099b-4cb0-92a1-00c053ba85c9>

(You can download this video along with the other Parts here):

<https://bittube.video/videos/watch/a1653cc6-099b-4cb0-92a1-00c053ba85c9>

If you have bought factory new primers, you only need to remove the old primers and can skip the rest of this part. If you have bought cases that already have their primers removed, skip this entire Part.

NOTE: I RECOMMEND YOU WEAR GLOVES AND SAFETY GLASSES FOR THIS PART.

- Step 1: Take your small punch (1 to 1.5mm), your hammer, a fired case, and the printed Primer Removal Cup tool (you can use a 3/8" socket or comparable metric socket if you don't have a 3D printer). Place the case into the Primer Removal Cup/socket, with the primer end facing down into the cup/socket. Position your punch so that it fits inside the flash hole on the case, and gently tap the punch so the primer is forced out of the case. Repeat this Step for each of your cases.



Step 1: This process is best understood by watching the video.

- Step 2: Use your needle-nosed pliers to hold a removed primer tight. Use your small screwdriver or dental pick to spin and lift the anvil out of the primer – some of these will seem hard to remove, but once you have a hold on the technique they come easily. Repeat this Step for each of your primers. Be sure not to lose any of the primer cups or anvils.



Step 2: This process is best understood by watching the video.

- Step 3: Scrape the un-burnt crud from the primer cups and anvils. You can throw this away; it is mostly just the old paper seal the factory primer had.



Step 3: Scraping out a primer cup

- Step 4: Use your flat piece of metal (you can use a wood block if you don't have a metal block handy), your 3.5mm punch, and your hammer to beat the dent out of your primer cup. Repeat this Step for each primer cup. Note that if your primer wall thickness is over spec and your 3.5mm punch is exactly 3.5mm, your punch may not fit into the primer cup – either get a 3.0mm punch or sand down the end of your 3.5mm punch so that it can fit (using sandpaper or a Dremel tool)

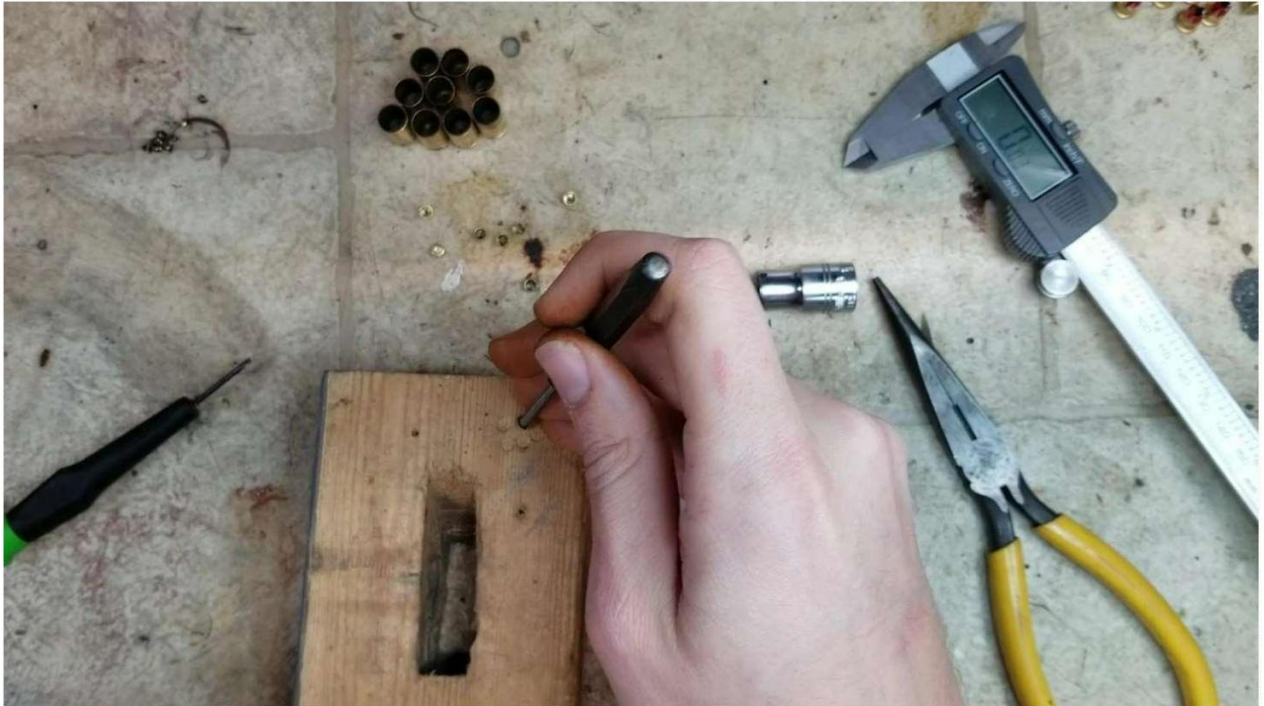

Step 4: Removing the dents in primer cups

- Step 5: Gather the empty Hiltis you dumped the powder out of in Part 1. Use your small screwdriver or dental pick to spread the hole at the point of the crimp (this hole has to be big enough you can stick your screwdriver or pick inside it) – ENSURE THERE IS NO GUNPOWDER LEFT INSIDE THE HILTI BEFORE INSERTING ANYTHING INTO THE HOLE IN THE CRIMP.



Step 5: Spreading the crimp. DO NOT insert your tool deep into the hole unless there is no gunpowder left.

- Step 6: After opening the crimp up enough, attempt to dump the Hilti over your gunpowder collection jar from the first Part – there can be trapped gunpowder still even after you think you’ve completed the first Part. If nothing comes out, you are good to proceed. If more powder spills out, ensure it all comes out before proceeding. Next, take your screwdriver or pick and gently scrape around the bottom of the Hilti, taking care not to press too hard and not scrape too quickly. Scrape all the way around the bottom of the Hilti twice, then dump the Hilti out onto a folded piece of paper (refer to the video for what this actually looks like!) Take the Hilti and again scrape around the bottom two more times, only this time you can press harder to help get your tool deeper into the case. Dump the Hilti onto the paper. Scrape the bottom one more time, you can move your tool quickly this time. Dump the Hilti again. Repeat this process for all the Hiltis you emptied on Part 1.



Step 6: Scraping the compound out of the Hilti

- Step 7: Take a primer cup and your sheet of paper (which has priming compound on it). Lay out a spare sheet of paper so you can catch any priming compound you may spill when doing this step. Gently tap your priming compound into the primer cup, using the folded piece of paper as a funnel. Fill the primer cup all the way up with uncompacted priming compound (just pour it in until it is full). You can re-use the spilled priming compound that you spill onto the spare sheet of paper.



Step 7: Gently tap the priming compound into the primer cup.

- Step 8: Take your 3.5mm punch, your 3.5mm hole punch, and the primer cup you just filled up. Use your hole punch to punch a 3.5mm disc of paper (you can just punch out 100 of these and keep a stockpile). Printer paper or notebook paper both work fine, avoid thick cardstock or glossy paper. Take your 3.5mm punch and compress the priming compound down into the primer cup – press down gently and evenly, DO NOT rotate the punch and do not press down too hard – just enough to compact the compound. Next, take a 3.5mm paper disc and push it down into the primer cup using your 3.5mm punch (you may need to use a smaller punch if your 3.5mm punch is a very snug fit). Repeat Step 7 then Step 8 for each primer cup you need to re-arm. Set these re-armed primers to the side, as you will use them in Part 3.



Step 8: Primer compound compacted; paper disc pressed down into the cup.

Part 3: Loading Rounds

This part involves taking your harvested powder, re-armed primers (or factory new primers), your cases, and your bullets and reloading live ammo. Refer to this video for a live demo of this Part:

<https://bittube.video/videos/watch/a88cc96a-95b1-4711-9e0e-3658b9ab2b0f>

(You can download this video along with the other Parts here):

<https://bittube.video/videos/watch/a88cc96a-95b1-4711-9e0e-3658b9ab2b0f>

Note: If you have proper reloading equipment, use it instead of following this Part – this Part will deal with reloading in absence of proper reloading tools, as some countries regulate them.

NOTE: I RECOMMEND YOU WEAR GLOVES AND SAFETY GLASSES FOR THIS PART.

- Step 1: Take your re-armed primers, anvils, empty cases, male and female primer seating tools, as well as your vise or c-clamp. Place the anvil point-up in the case's primer pocket, then set the primer on top of it. You can pinch straight down with your thumb to get the primer cup to start going into the pocket. Take your male and female seating tools and place the case in them. Close the tools together in a vise or c-clamp so that the primer is forced into the case. If using a c-clamp, press the primer in a half turn, then back off a quarter turn to ensure that you press the primer in straight – forward $\frac{1}{2}$, back $\frac{1}{4}$, forward $\frac{1}{2}$, back $\frac{1}{4}$, etc. Only push to the point you feel a change in resistance – at this point, stop and check how far you have driven the primer in. You want the primer to be slightly recessed past the face of the head of the case. If your primer protrudes at all, place the case back into the seating tools and press it in a little further.



Step 1: Pressing a primer into place

- Step 2: Take your case sizing tools, your primed case, and your vice or c-clamp. Insert your case into your sizing tool fully (so that the case is stuck as far in as it can go). Use your vise or c-clamp to pinch the sizing tool along its direction of travel (try and close it more, the split in the tool will be parallel to the jaws of your vice or c-clamp). Pinch tight, until you feel excessive resistance – you are re-shaping the case when you do this, so it will require a little force. Remove the sizing tool from your vise or c-clamp, and use pliers to spin the case 1/3 of a rotation in the case sizing tool. Pinch it again. Rotate another 1/3 of a rotation, and pinch one more time. Once this is done, you can use pliers to remove the case from the tool.

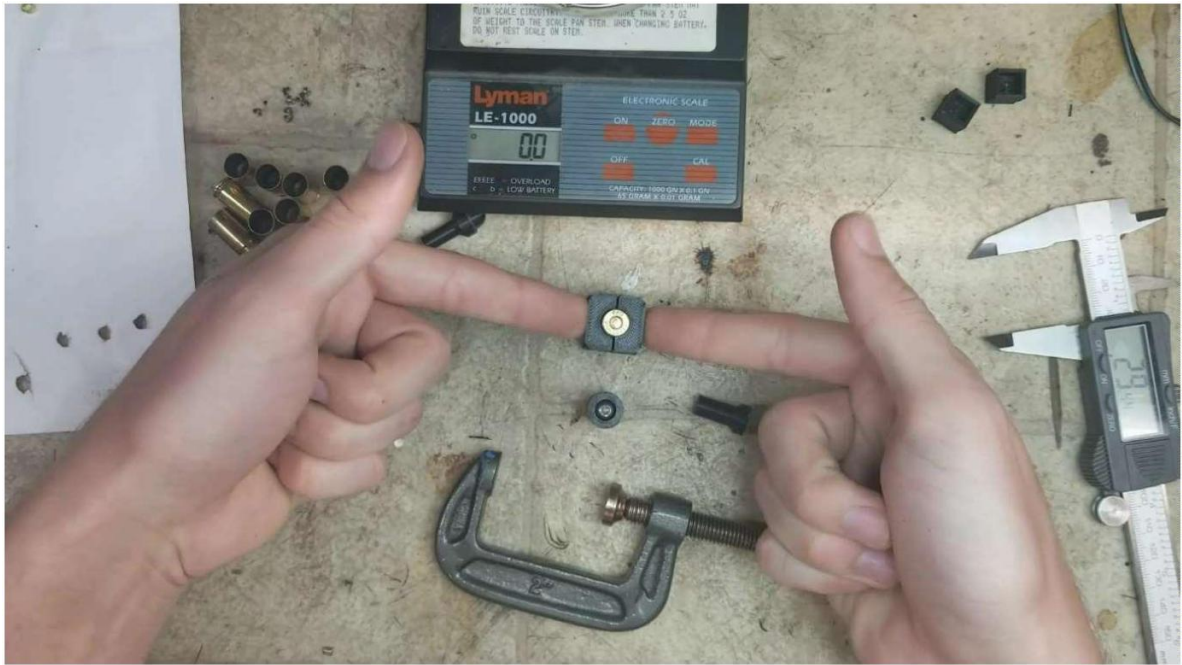

Step 2: Showing the sides of the sizing tool that should be pinched (imagine my hands are the vice jaws)

- Step 3: Take your scale and jar full of harvested powder, as well as your re-sized, primed case. Measure out your powder load using your scale (you could use a printed power measure, but I do not trust them enough – I recommend you measure powder out on a scale). After you have measured your powder load, dump it into your case (use a funnel or pouring cup, or the notebook paper trick used with the primer re-arming). Visually inspect the powder load in the case to ensure it does not look too full – it should not be taking up more than half the case.



Step 3: Dumping 3.5gr of powder into the case.

- Step 4: Take your charged case (has powder and a primer), a new bullet (115, 124, 147gr, or any other appropriate 0.355" projectile), your vise or c-clamp, and calipers or other measuring tool. Rock the bullet into the mouth of the case (take care not to spill any gunpowder). If you have trouble getting your bullets to start in the case, dump your powder back into your reservoir and practice getting a bullet started in the case – you have to rock it in while pressing it down into the case. If you have trouble, you can press the case mouth forming tool into the case mouth to round it out and flare it slightly so that the bullet can start a little easier. This may take some practice, but with the right technique it is easy to do – watch how I do it in the video.



Step 4: Rocking a bullet into the case.

- Step 5: Use your c-clamp or vise to set the bullet into the case. You will want the overall length of your rounds to be consistent, so use calipers or a ruler to ensure your round is between 26 and 29mm overall length. Repeat this process for each round.



Step 5: Seating bullet into case.

Load Data

Across the development cycle of this project, I tried several load combinations. While this data is still relevant from a standpoint of reference, note that the crimping of cases and total setback of rounds was not controlled perfectly, and thus data may differ slightly from what you may find.

Note: From our tests, it seems Hilti have Lovex D036 Powder (or equivalent) loaded in them.

Note: Red and Yellow Hiltis have the same type of gunpowder, just different amounts. Black Hiltis have a slower burning powder.

Note: The 115gr 147gr bullets used were true 0.355" projectiles, the 124gr bullets used were 0.356" – higher velocities when comparing 124 to 115 are likely due to the higher pressure the 124s took to propel due to their slightly larger diameter.

This table is for reference – I do not necessarily think these loadings are that great.

| Bullet Weight (grains) | Propellant Type – Weight (grains) | Velocity |
|------------------------|-----------------------------------|----------|
| 115 | RED/YELLOW - 2.5 | 610fps |
| 115 | BLACK – 3.5 | 760fps |
| 124 | RED/YELLOW - 2.5 | 625fps |
| 124 | BLACK – 3.5 | 755fps |
| 147 | RED/YELLOW - 3.5 | 825fps |
| 147 | BLACK – 3.5 | 740fps |

RECOMMENDED LOADINGS

I am going to work under the assumption that sub-sonic 9mm loadings are preferred here. Note that if you are using these in an FGC-9 (or other blowback 9mm that lacks an extractor) you might want to limit your powder loadings to 3.5gr, as higher powder loads net higher pressures, which prevents reliable extraction due to sealing the case in the chamber. I do not think Black Hilti powder is worth using at all, stick to Red or Yellow. These loadings should be capable of cycling tilt-action pistols as well.

Note: Based on your exact bullets, firearm, and tool setup, your velocity could differ – ensure you are not going to accidentally load supersonic rounds when you are expecting to load subsonic ones. Load a few, and test fire them over a chronograph if you can.

| Bullet Weight (grains) | Propellant Weight (grains) | Velocity |
|------------------------|----------------------------|----------|
| 115 | 4.1 | <1050fps |
| 124 | 4.2 | <1050fps |
| 147 | 4.3 | <1050fps |

Existing Tests

As of the date of this document's publication, I have tested the loads listed above in four different firearms:

An FGC-9 (with ECM barrel) (200+ rounds)

A Browning Hi-Power (50 rounds)

A FM Argentine Hi-Power (25 rounds)

A Glock 17 (10 rounds)

The FGC-9 will run even the underpowered loads (because it is simple blowback), the handguns all need the 'recommended' loads in order to cycle – they still fire with the underpowered loads, but won't cycle the slide fully.

Note: I did experience some failures to extract on the FGC-9 tests when using the recommended loads as they are higher pressure, which makes blowback extraction more haphazard. The barrel I had in my FGC-9 for these tests isn't perfectly formed, which is probably the reason for the failures – but it's worth noting that if you have issues with extraction of this ammo when other ammo works fine, you might want to load a little less powder.

Note: If you are using re-armed primers, it is much more important than with factory primers that your firing pin be perfectly centered on the primer, and that your firing pin be straight and shaped correctly (if you're using an FGC-9). While I had no issues with the pistols firing the re-armed primers, my FGC-9 would sometimes take two hammer-strikes to fire off a primer – simply because my firing pin channel was drilled a little too low. The primer compound these Hiltis have seems to be slightly less volatile than what standard centerfire primers have.

Notes/Words of Wisdom/Quality Control

Be sure to test your ammo in a safe manner. Build a bullet/sound trap and shoot in a basement, use a sound trap and shoot in the woods, etc. I would recommend testing one round out of every batch of ten, just to be sure your exact process and tools worked properly. While this is a safe process when done properly, remember to wear eye and hand safety gear when appropriate.

For quality control, there are several steps you can take to check each round without firing it:

- After pressing in your primer in Part 3, look down into the flash hole on the case and ensure you can see the bottom of the anvil – if you can't, your anvil was seated improperly and that case is useless.
- Make sure you double check powder loads! Do not place all your trust in printed powder measures, I really do recommend you get a scale and measure things out.
- Measure case overall length! You can have some rounds that are short by a millimeter or two, but do not exceed that – and especially do not have rounds that are too long. Try to end up between 26 and 29mm overall length.
- Test each round's sizing by dropping it into your 9x19mm barrel. They should be able to seat fully without excessive sticking – if they fit tight and you are using a properly shaped 9x19mm chamber, ensure you used the sizing tool correctly.

FAQ/Troubleshooting

My primers do not fire when hit by the firing pin!

Ensure that you filled each primer cup up fully with loose compound, compacted it, and used a paper disc. Ensure that your firing pin is in good shape, and that it is perfectly centered (within 0.1mm) about the center of the primer.

I am having trouble getting bullets to start into their case!

Use a rocking motion to get them to start. This may take a little practice to get the hang of, but my girlfriend was able to do it – you should be able to as well. Rock the bullet into the case, pushing down while you do so. If you still have trouble, use the Case Mouth Forming Tool to ensure the case mouth is fully round and wide enough to accept a bullet.

My rounds will not extract (FGC-9)!

Ensure that you used the case sizing tool properly. Ensure that your FGC-9 barrel is both formed properly (to spec) and that it is headspaced properly (follow the FGC-9's tutorial for this).

If you have run into a serious issue that you cannot otherwise solve yourself, and you think it might be something that isn't your fault, please email me: ivanthetroll@protonmail.com. There is always a chance I have overlooked something and can get the solution added to this document.

Acknowledgements

Many thanks to JStark, who helped guide me through the laws and availability of the supplies needed in Europe. Thanks to the anons who helped kick a little money into the project so that I could further develop load data on a wider variety of projectiles. Thanks to those who helped proofread this document and catch errors and confusing wording.